

SONNENSTÄRKE

SONNENSTÄRKE uses the latest German technology in all manufacturing processes, and premium certified materials from top manufacturers in the world, to ensure exceptional module quality, and high reliability. All modules undergo a profound testing processes, and assembled by highly trained, and passionate, professionals.

KEY FEATURES



Positive tolerance

+5w tolerance which generates higher output authenticity



PID Resistant

Anti-PID materials lead/ contribute to limited power degradation



Severe weather resilience

Certified to withstand wind load (2400 Pascal) and snow load (5400 Pascal)



Withstanding extreme environmental conditions

High salt mist and ammonia resistance according to IEC standard



Competent quality control management

In-house testing modules using electroluminescent (EL) and High Voltage. Certified factory: ISO9001-2015 Quality management system.

LINEAR PERFORMANCE WARRANTY

10 years product warranty 25 years linear power performance warranty

- Linear Performance Warranty
- Standard Performance Warranty



GUARANTEED BY

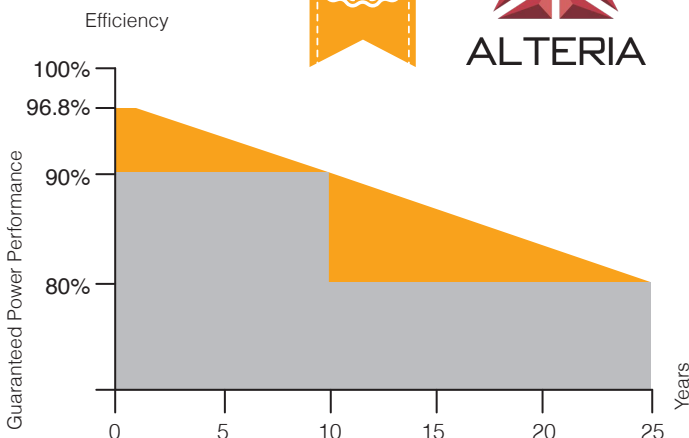

SONMMP-72F-HV

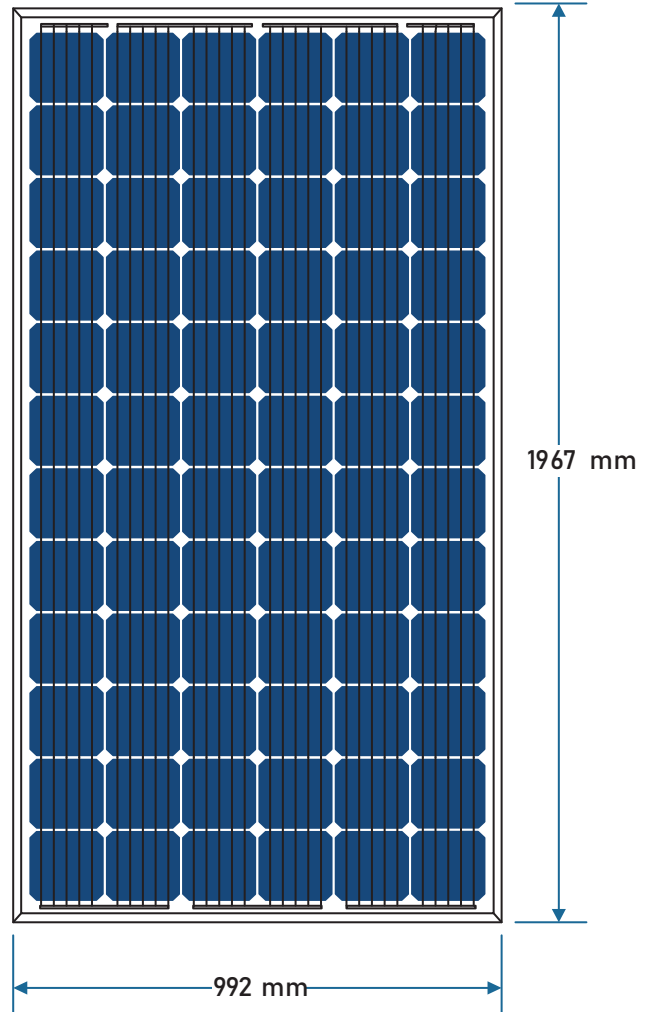

PERC TECHNOLOGY

370-380W

power output range

UP TO 19.47%

Maximum Efficiency

72 CELLS

PRODUCT CERTIFICATES

- IEC 61215:2005
- IEC 61730-1:2004
- IEC 61730-1:2004/AMD1:2011
- IEC 61730-1:2004/AMD2:2013
- IEC 61730-2:2004
- IEC 61730-2:2004/AMD1:2011



Technical Specification

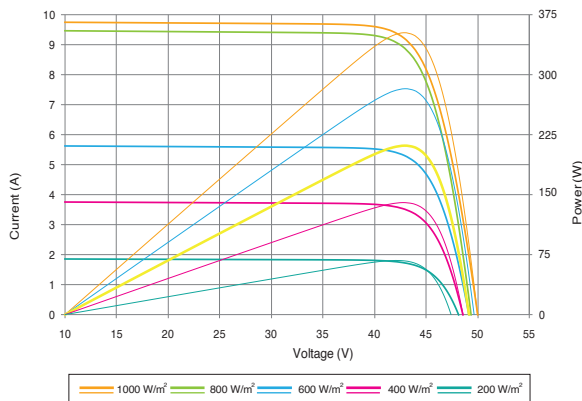
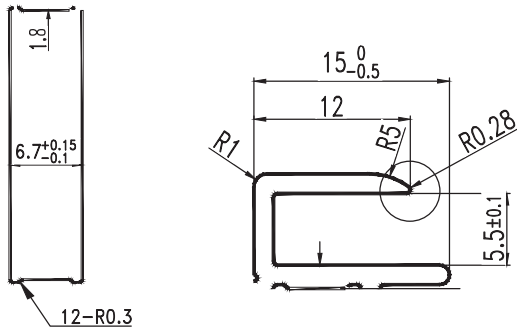
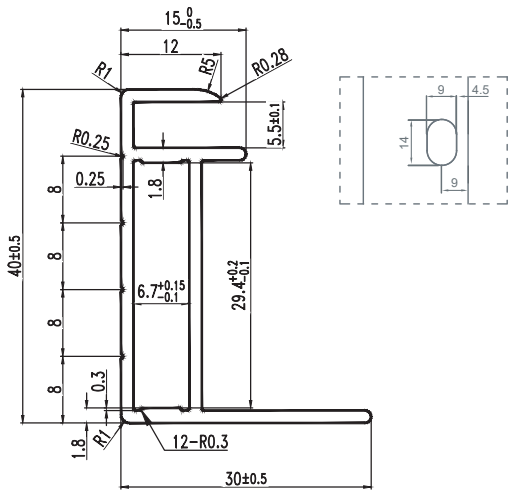
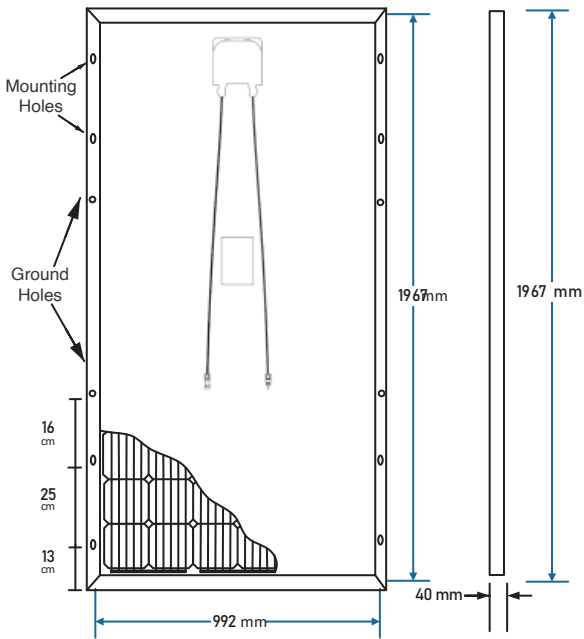

Electrical Data under STC

(Standard Test Conditions: 1000 W/m², 25 °C, AM 1.5)

Output Power (Pmax)	370 Wp	375 Wp	380 Wp
Voltage (Vmpp)	39.32 V	39.44 V	39.56 V
Current (Impp)	9.41 A	9.52 A	9.63 A
Open Circuit Voltage (Voc)	48.53 V	48.63 V	48.73 V
Short Circuit Current (Isc)	10.01 A	10.09 A	10.17 A
Efficiencies	18.96%	19.22%	19.47%

Electrical Data at 800 W/m², NOCT (20°C +/- 2°C), AM

Output Power (Pmax)	302 Wp	305 Wp	308 Wp
Voltage (Vmpp)	40.56 V	40.64 V	40.72 V
Current (Impp)	7.45 A	7.51 A	7.57 A
Open Circuit Voltage (Voc)	48.63 V	48.73 V	48.83 V
Short Circuit Current (Isc)	7.98 A	8.13 A	8.28 A

Temperature Data

Power Temperature Coefficient (TC Pmpp)	-0.38 %/°C
Voltage Temperature Coefficient (TC Voc)	-0.36 %/°C
Current Temperature Coefficient (TC Isc)	+0.07 %/°C

Packaging Specifications

Pallet Dimensions	203 x 113 x 100 cm (L x W x H)
Weight Pallet	ca. 550 kg
Modules per Pallet	26

Additional Data

Cell Type	Mono-crystalline PERC 156.75x156.75mm
No. of cells	72 (6x12)
Dimensions	1967x992x40mm
Maximum System Voltage	1500 V
Front Glass	3.2mm, Special hardened low-iron glass with anti-reflex coating; glare reduced to a minimum
Frame	Anodized Aluminium Alloy
Module Connection	IP 67 no potting, 2 x approx. 0.95 m solar cable Ø 4 mm ² , GZX

Contact Us: 25A, Ismail Mohamed St., Zamalek, Cairo, Egypt
www.sonnenstarke.com - info@sonnenstarke.com

Teriak Industrial Group, headed by CEO Samir Teriak, established SONNENSTÄRKE in Cairo, Egypt. A leading regional PV manufacturer, SONNENSTÄRKE uses the latest German technology, German machinery, and German expertise in its manufacturing process.